

- ▲ BRASS, .023 THICK PER MIL-C-50 OR ASTM B16.
- ▲ 2.54 μm [.000100] MIN TIN OR TIN LEAD PER MIL-T-10727 OVER
2.54 μm [.000100] MIN COPPER PER MIL-C-14550A.
- 3. FERRULE SELECTION PROCEDURE:
 - A. SELECT THE DESIRED CABLE CLAMP FROM ANY OF THE FOLLOWING DRAWINGS:
5745171, 5745172, 5745173, 5745174, 5745175, 5745854, 5747099,
5745833, 5747100, 5747098, 5745919, 5745652, 5745653
 - B. VERIFY THAT THE CHOSEN CABLE CLAMP IS AVAILABLE.
 - C. SELECT AN INNER FERRULE PART NUMBER TO MATCH THE CABLE CLAMP SIZE AND CABLE DIAMETER TO BE USED.
 - D. USE THE OUTER FERRULE LISTED WITH THE CHOSEN INNER FERRULE.
 - E. SEE SPLIT RING FERRULES ON DRAWING 745508 FOR ADDITIONAL OPTIONS.

- ▲ 2.54 μm [.000100] MIN TIN, OVER
2.54 μm [.000100] MIN COPPER.
- ▲ OBSOLETE
- ▲ D DIMENSION APPLIES TO STYLE II OR STYLE III FERRULES ONLY.

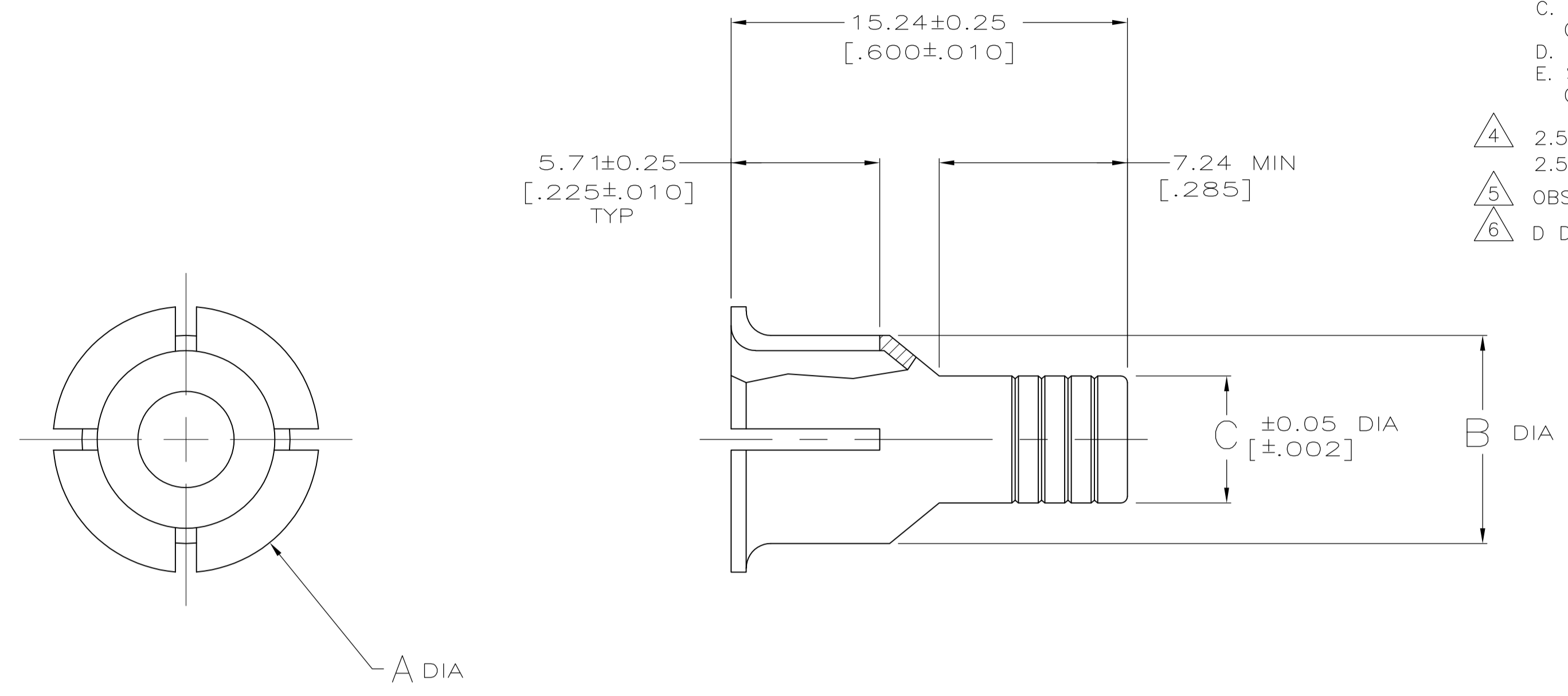

STYLE I

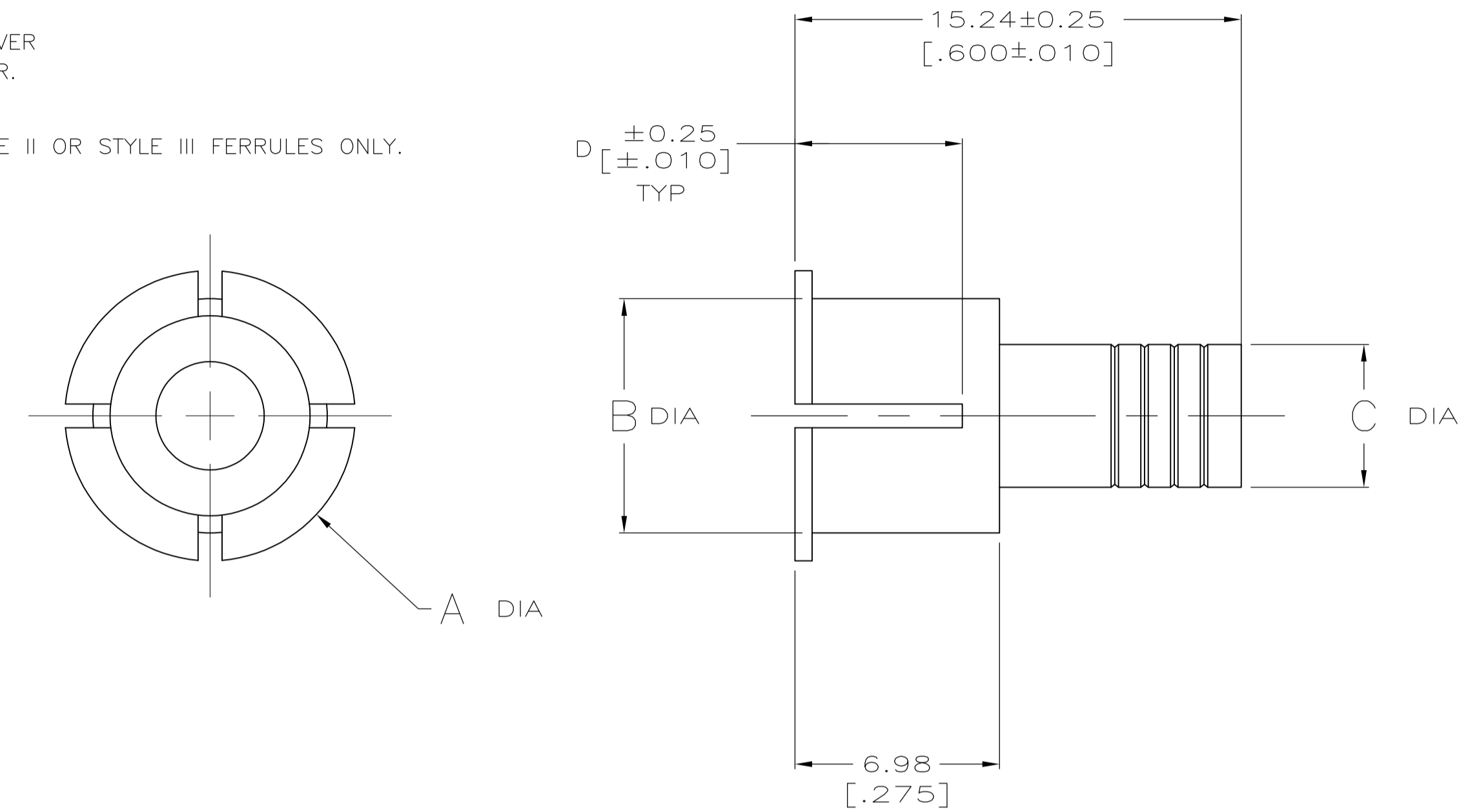

STYLE II

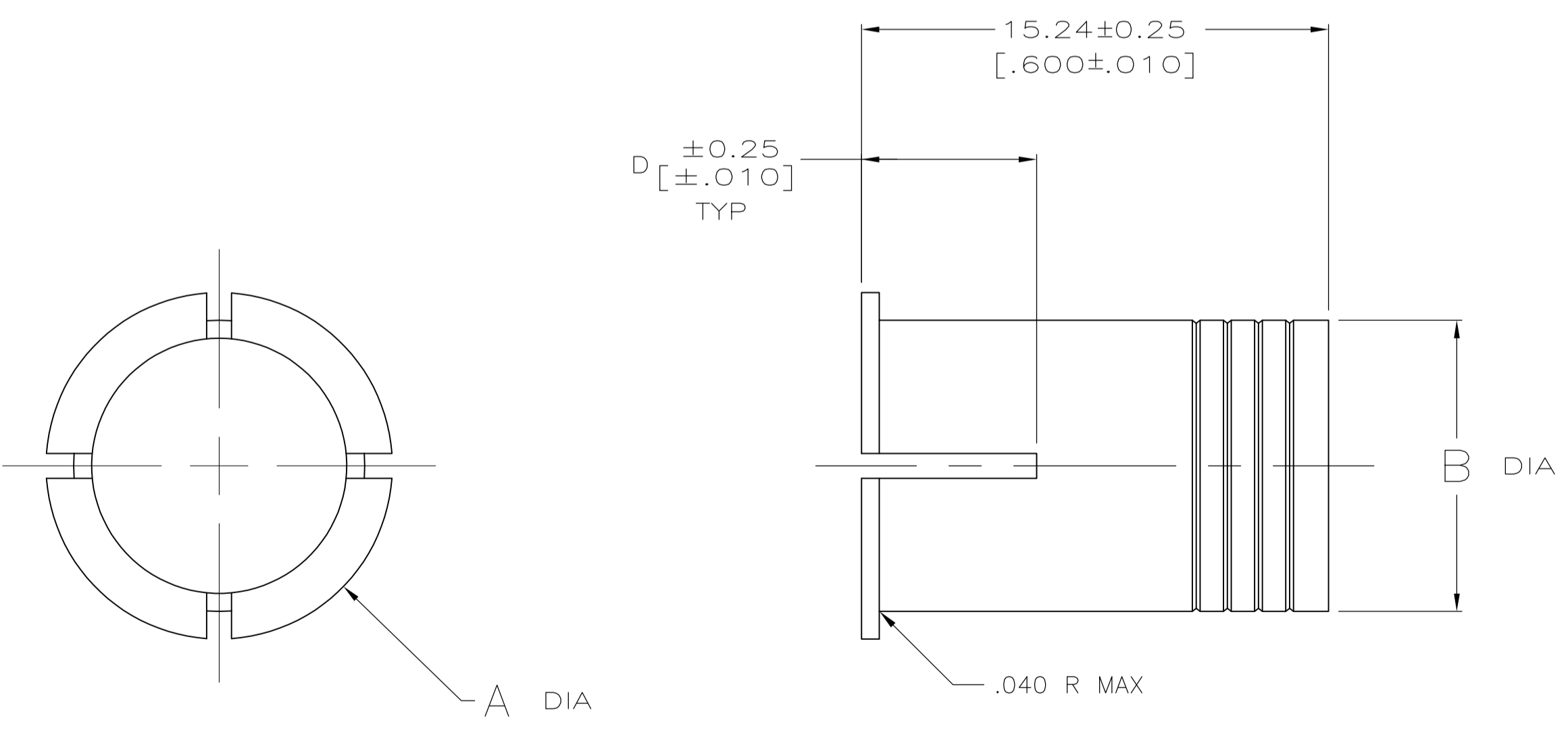

STYLE III

4-745130-5	▲	1, 2, 5	.230-.280	I OR II	5.72 (0.225)	5.72 (0.225)	8.00 (0.315)	10.16 (0.400)	7-745129-9
4-745130-5	▲	2, 3, 4	.230-.280	I OR II	4.70 (0.185)	5.72 (0.225)	9.50 (0.374)	11.56 (0.455)	7-745129-8
4-745130-3		5	.600-.650	I OR II	5.72 (0.225)	15.11 (0.595)	17.65 (0.695)	19.94 (0.785)	▲ 7-745129-7
4-745130-2		4	.480-.530	I OR II	5.72 (0.225)	11.94 (0.470)	15.11 (0.595)	17.40 (0.685)	7-745129-6
4-745130-1		3, 5	.380-.430	I OR II	5.72 (0.225)	9.50 (0.374)	11.94 (0.470)	14.22 (0.560)	7-745129-5
4-745130-2		3, 5	.480-.530	III	5.72 (0.225)	---	11.94 (0.470)	14.22 (0.560)	7-745129-4
3-745130-8		2, 3, 4	.190-.240	I OR II	5.72 (0.225)	4.88 (0.192)	9.50 (0.374)	11.56 (0.455)	7-745129-3
3-745130-9		2, 3, 4	.300-.350	I OR II	5.72 (0.225)	7.47 (0.294)	9.50 (0.374)	11.56 (0.455)	7-745129-2
4-745130-1		2, 3, 4	.380-.430	III	5.72 (0.225)	---	9.50 (0.374)	11.56 (0.455)	7-745129-1
3-745130-8		1, 2, 5	.190-.240	I OR II	5.72 (0.225)	4.88 (0.192)	8.00 (0.315)	10.16 (0.400)	7-745129-0
4-745130-0	▲	1, 2, 5	.320-.370	III	5.72 (0.225)	---	8.00 (0.315)	10.16 (0.400)	6-745129-9
1-745130-6	▲	1, 2, 5	.230-.280	I OR II	5.72 (0.225)	5.72 (0.225)	8.00 (0.315)	10.16 (0.400)	▲ 3-745129-4
1-745130-6	▲	2, 3, 4	.230-.280	I OR II	5.72 (0.225)	5.72 (0.225)	9.50 (0.374)	11.56 (0.455)	▲ 3-745129-2
1-745130-2		5	.480-.530	I OR II	5.72 (0.225)	11.94 (0.470)	17.65 (0.695)	19.94 (0.785)	▲ 3-745129-0
1-745130-3		5	.600-.650	I OR II	5.72 (0.225)	15.11 (0.595)	17.65 (0.695)	19.94 (0.785)	2-745129-9
1-745130-4		5	.700-.750	III	5.72 (0.225)	---	17.65 (0.695)	19.94 (0.785)	▲ 2-745129-8
1-745130-1		4	.380-.430	I OR II	5.72 (0.225)	9.50 (0.374)	15.11 (0.595)	17.40 (0.685)	▲ 2-745129-7
1-745130-2		4	.480-.530	I OR II	5.72 (0.225)	11.94 (0.470)	15.11 (0.595)	17.40 (0.685)	▲ 2-745129-6
1-745130-3		4	.600-.650	III	5.72 (0.225)	---	15.11 (0.595)	17.40 (0.685)	▲ 2-745129-5
745130-9		3, 5	.300-.350	I OR II	5.72 (0.225)	7.47 (0.294)	11.94 (0.470)	14.22 (0.560)	▲ 2-745129-4
1-745130-1		3, 5	.380-.430	I OR II	5.72 (0.225)	9.50 (0.374)	11.94 (0.470)	14.22 (0.560)	▲ 2-745129-3
1-745130-2		3, 5	.480-.530	III	5.72 (0.225)	---	11.94 (0.470)	14.22 (0.560)	▲ 2-745129-2
745130-8		2, 3, 4	.190-.240	I OR II	5.72 (0.225)	4.88 (0.192)	9.50 (0.374)	11.56 (0.455)	▲ 2-745129-1
745130-9		2, 3, 4	.300-.350	I OR II	5.72 (0.225)	7.47 (0.294)	9.50 (0.374)	11.56 (0.455)	▲ 2-745129-0
1-745130-1		2, 3, 4	.380-.430	III	5.72 (0.225)	---	9.50 (0.374)	11.56 (0.455)	▲ 1-745129-9
745130-8		1, 2, 5	.190-.240	I OR II	5.72 (0.225)	4.88 (0.192)	8.00 (0.315)	10.16 (0.400)	▲ 1-745129-8
1-745130-0		1, 2, 5	.320-.370	III	5.72 (0.225)	---	8.00 (0.315)	10.16 (0.400)	▲ 1-745129-7
745130-8	▲	1	.190-.240	III	5.72 (0.225)	---	4.88 (0.192)	6.99 (0.275)	▲ 1-745129-6

OUTER FERRULE P/N	FINISH	FOR CABLE CLAMP SIZE(S)	CABLE DIA RANGE	STYLE	D	C	B	A	TE PART NUMBER
-------------------	--------	-------------------------	-----------------	-------	---	---	---	---	----------------

THIS DRAWING IS A CONTROLLED DOCUMENT.

APPROVED: D. BROCKWAY, 20MAY04
 CHK: C. ROHDE, 20MAY04
 NAME: M. WALMSLEY, 20MAY04

Tyco Electronics Corporation
 Harrisburg, PA 17105-3608

FERRULE, INNER, AMPLIMITE HDP-20

SIZE: A1, CAGE CODE: 00779, DRAWING NO: 745129, RESTRICTED TO: --

WEIGHT: --, SCALE: 4:1, SHEET: 1 OF 1, REV: --

CUSTOMER DRAWING